

SEETRONIC

Product Data Sheet

Product Type

XLR Plug

Product Model

SCSF3-BG

Customer Name

Manufacturer	Prepared	Checked	Approved

Customer	Received	Checked	Confirmed



Product Data Sheet

Product Type	XLR Plug	
Product Model	SCSF3-BG	

Product Features

- 3-core XLR female cable connector with black plated housing and gold plated contacts
- The metal housing adopts external thread design
- Two cable clamps are provided for different cable diameters; black clamp 3.5-6mm; white clamp 6-8mm
- No colored ring design which is more compact and can save space
- Colored boots available for coding or identification
- The boot is equipped with a polyurethane sealing sleeve to prevent the cable from being affected by bending pressure to the greatest extent



Product Data Sheet

Product Parameters

Item	Specification
Connection Type	XLR
Gender	Female

Electrical Parameters

Item	Specification
Capacitance between contacts	≤ 4 pF
Contact resistance	≤ 3 m Ω
Dielectric strength	1.5 kV DC
Insulation resistance	> 10 G Ω (initial)
Rated current per contact	16 A
Rated voltage	< 50 V



Product Data Sheet

Mechanical Parameters

Item	Specification
Cable O.D.	Black Strain relief: 3.5-6 mm White Strain relief: 6-8 mm
Insertion force	≤ 20 N
Withdrawal force	≤ 20 N
Service life	> 1000 mating cycles
Cable size	Max. 2.5 mm ² Max. 14 AWG
Locking device	Latch lock



Product Data Sheet

Material and Environmental Parameters

Item	Specification
Boot	PA
Contacts	Cu alloy
Contact plating	Au
Insert	PA 尼龙
Housing	Zinc diecast
Housing plating	Black plating
Strain relief	POM
Flame-retardant grade	UL 94 HB
Protection class	IP40
Temperature range	-30°C ~ +80°C

Standards and Certifications

Standards	IEC 61076-2-103
Solderability	Complies with IEC 68-2-20



Product Data Sheet

Product Drawing

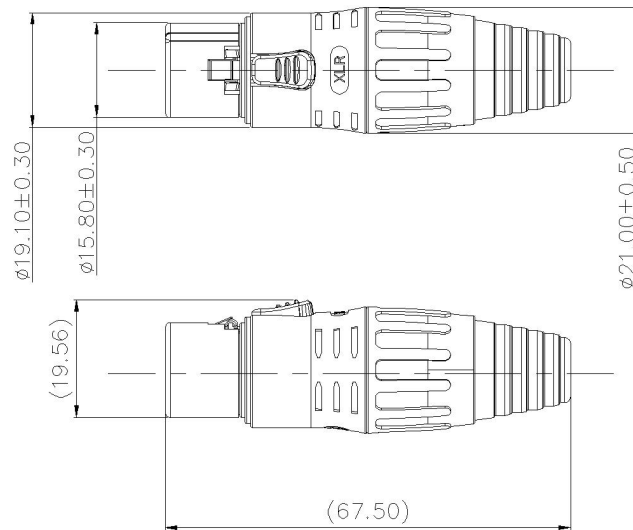

Unit: mm

Packaging Method

1 pc per bag (include 1 pc each of inner core assembly, housing, black and white cable clamps, boot)
80 pcs per inner carton, 5 inner cartons per master carton (400 pcs per master carton)

Accessory

- | | |
|----------------------------------------------------|----------------------------------------------|
| <input checked="" type="checkbox"/> No accessories | <input type="checkbox"/> Back fastener plate |
| <input type="checkbox"/> Screws and Nuts | <input type="checkbox"/> Other |



Product Data Sheet

Assembly Instructions

(1) Put the cable through the boot.

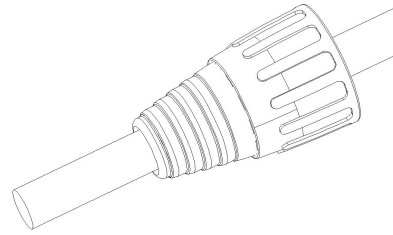

(2) Strip the cable in the size as shown.

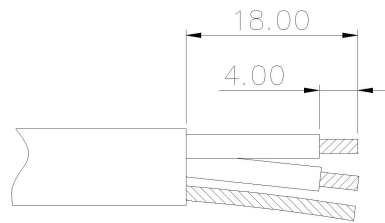

(3) Insert the conductor of the cable into the terminal of the inner core and solder.

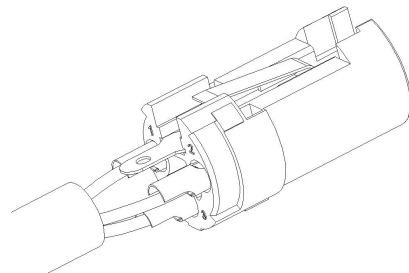

(4) Insert cable into the clamp and clip into the inner core bayonet.

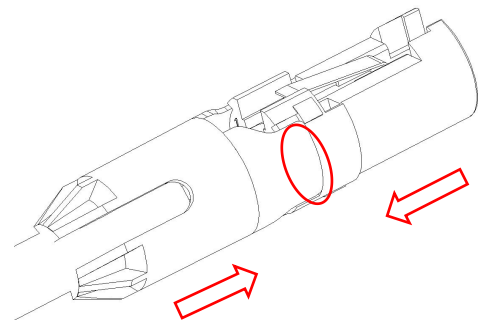

Product Data Sheet

- (5) Push the inner core component and clamp into the housing. The two protruding ribs of the inner core component should correspond to the two grooves inside the housing.

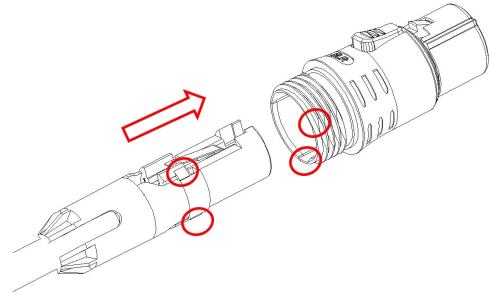

- (6) After the assembly of the clamp, inner core and housing, tighten the boot in a clockwise direction.

